

# JFR481 Radar Wave Level Gauge



## INTRODUCTION

The JFR4 radar wave level meter is a smart, non-contact liquid level-measuring instrument that uses 80GHz high-frequency. The antenna is further enhanced for optimal processing. The new, fast microprocessor can perform signal analysis and processing at a faster rate, ideal for liquid storage tanks.

Provides RS-485 digital signals and emits 4~20mA analog signals, which can be easily connected to back-end extension applications.

The product is dustproof and waterproof, suitable for outdoor or industrial environments, and can be used for industrial measurement of liquid levels in barrels and tanks, and other environmental applications.

## SPECIFICATIONS

Medium	Liquids
Measurement range	35m
Frequency	80GHz
Power supply	24VDC
Power consumption	Max.0.54W
Blind distance	0.05m
Resolution	1.6 uA
Accuracy	±1mm
Analog output	4-20mA
Beam angle	6°
Operating temp. range	-40~150°C
Antenna material	φ45mm · PTFE
Operating pressure	0~40 bar
Connection	G1-1/2" A
Fault output	20.5mA ; 22mA ; 3.9mA
Damping time	0~100s adjustable
Cover window	PC
Cover seal material	Fluorine rubber
Cover material	Aluminum /IP67
Cable inlet	M20*1.5 (cable outer diameter: 6~9mm) Blind plug 20*1.5
Weight	1.5KG
Shock resistance	Mechanical vibration 10m/s <sup>2</sup>



## WORKING PRINCIPLE

The radar level gauge transmits a continuous radar wave signal from the antenna. This signal is a frequency-modulated continuous wave (FMCW). There is a frequency difference between the continuous wave emitted from the radar level gauge antenna and the echo returned from the surface of the object. The frequency difference is proportional to the distance between the antenna and the surface of the object. After receiving the echo, the electronic components are processed using a unique high-precision algorithm, the Fast Fourier Transform (FFT), which enables the instrument to accurately measure the height of the liquid level.

## SCOPE OF APPLICATION

It is used in measurement scenarios such as liquid level monitoring and control of barrels and tanks in industrial, petrochemical, water conservancy and hydropower fields.

1. Water or wastewater treatment equipment, such as used in barrels, tanks, wells, etc.
2. Raw liquid materials such as edible oils, sauces, heavy oils, beverages, etc.

## FEATURES

- Non-contact measurement, no wear and tear, and no pollution.
- Small antenna size, easy to install.
- The measurement blind spot is small, therefore particularly effective on the measurement of small storage tanks.
- The beam angle is small, the energy is concentrated, and the echo ability is enhanced, making it conducive in avoiding interfering objects.
- Unaffected by corrosion, foam, and viscosity.
- Unaffected by changes in water vapor, temperature and pressure in the atmosphere.
- High signal-to-noise ratio, even in the case of fluctuations.
- The 80GHz frequency is the best choice for measuring low dielectric constant media, and it is suitable for measuring material working conditions with dielectric constant  $\geq 1.8$  of the medium under test.

## APPEARANCE SIZE

(unit: mm)

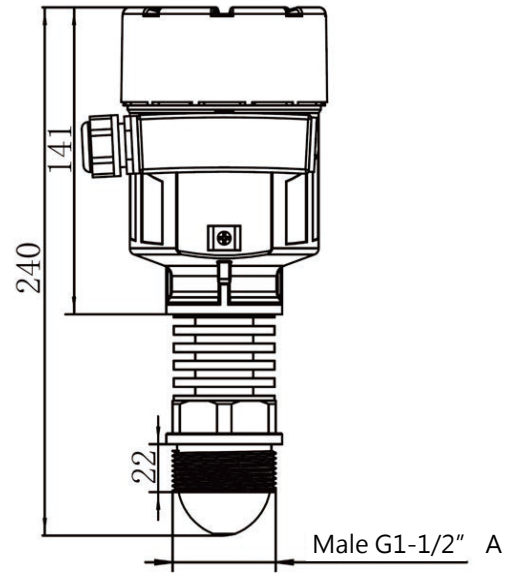

## ORDER INFORMATION

**JFR48100 - DCFA** 13 14 15 16 17 18 **BC** 21 **A** 23 **AB**

Connection size

<span style="border: 1px solid black; border-radius: 50%; padding: 2px;">13</span> <span style="border: 1px solid black; border-radius: 50%; padding: 2px;">14</span>	<span style="border: 1px solid black; border-radius: 50%; padding: 2px;">15</span> <span style="border: 1px solid black; border-radius: 50%; padding: 2px;">16</span>	<span style="border: 1px solid black; border-radius: 50%; padding: 2px;">17</span> <span style="border: 1px solid black; border-radius: 50%; padding: 2px;">18</span>
Flange connection	B1 : 1-1/2"	17 : Male G
AD : DIN		

21 Output/Input

A : 4~20mA / 24V DC Two-wire  
 C : 4~20mA / 24V DC Four-wire  
 E : RS485 / Modbus(Housing/Ingress Protection, choose C)

23 Housing/Ingress Protection

C : Aluminium/IP67(Ps. Two-wire)  
 D : Double cavity aluminum/IP67(Ps. Four-wire)

