

## TWO-WAY GLOBE CONTROL VALVES V16/2 (EN)

### DESCRIPTION

The ADCATrol V16/2 is a series of single seated, two-way globe control valves designed for simple process engineering and industrial applications with non-critical operating conditions. These valves can be assembled with pneumatic, hydraulic or electric actuators, for modulating and shut-off control tasks.

### MAIN FEATURES

- Compact and cost-effective.
- Modular design to meet process requirements.
- Stem guided (up to DN 50) and post guided (from DN 65 to DN 100).
- Parabolic plug design.
- Stainless steel trim.

### OPTIONS AND ACCESSORIES:

- Bonnet extension for high and low temperatures.
- Various stem sealing options including bellows sealing.
- Soft or stellite valve sealing.
- Reduced bore trims.
- Silencers.

### USE:

- Saturated and superheated steam.
- Hot and superheated water.
- Air, gases and others.

### AVAILABLE MODELS:

- V16/2G – SG iron.
- V16/2S – carbon steel.
- V16/2i – stainless steel.

### SIZES:

DN 15 to DN 100.

### CONNECTIONS:

- V16/2G – Flanged EN 1092-2 PN 16.
- V16/2S and V16/2i – Flanged EN 1092-1 PN 16 or PN 40.
- Standard PN 16 DN 65 flanges are supplied with 4 holes. 8 holes, according to EN 1092-1/-2, on request.





#### CE MARKING – GROUP 2 (PED – European Directive)

PN 16	PN 40	Category
DN 15 to 50	DN 15 to 32	SEP
DN 65 to 100	DN 40 to 100	1 (CE marked)

#### BODY LIMITING CONDITIONS

V16/2G **		V16/2S *				V16/2i *			
FLANGED PN 16		FLANGED PN 16		FLANGED PN 40		FLANGED PN 16		FLANGED PN 40	
ALLOW. PRESSURE	RELATED TEMP.	ALLOW. PRESSURE	RELATED TEMP.	ALLOW. PRESSURE	RELATED TEMP.	ALLOW. PRESSURE	RELATED TEMP.	ALLOW. PRESSURE	RELATED TEMP.
16 bar	-10 °C / 50 °C	16 bar	-10 °C / 50 °C	40 bar	-10 °C / 50 °C	16 bar	-10 °C / 50 °C	40 bar	-10 °C / 50 °C
14,7 bar	200 °C	13,3 bar	200 °C	33,3 bar	200 °C	13,4 bar	200 °C	33,7 bar	200 °C
13,9 bar	250 °C	12,1 bar	250 °C	27,6 bar	300 °C	12,7 bar	250 °C	29,7 bar	300 °C
12,8 bar	300 °C	11 bar	300 °C	25,7 bar	350 °C	11,8 bar	300 °C	28,5 bar	350 °C
11,2 bar	350 °C	10,2 bar	350 °C	23,8 bar	400 °C	11,4 bar	350 °C	27,4 bar	400 °C

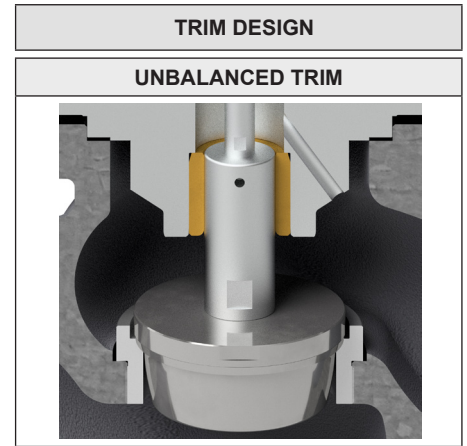

\* Rating according to EN 1092-1:2018; \*\* Rating according to EN 1092-2:2007.

BONNET DESIGN	
STANDARD	EXTENDED
 -10 °C to 250 °C	 Above 250 °C

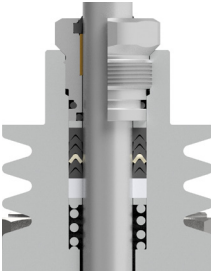
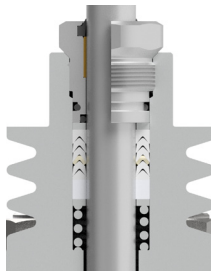
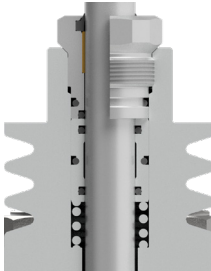
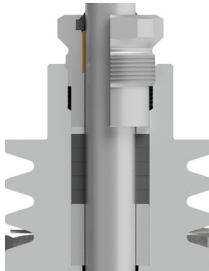
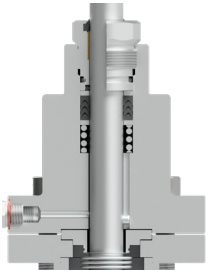
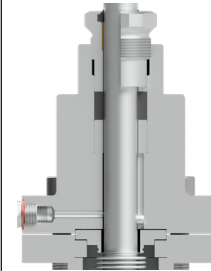

STEM SEALING					
PTFE/GR V-RINGS (V1.2)	PTFE V-RINGS (V2.2)	EPDM (EP1)	GRAPHITE (G1)	BELLOWS	
				(BV1)	(BG1)
 -10 °C to 220 °C	 -10 °C to 180 °C	 -10 °C to 150 °C *	 -10 °C to 400 °C	 -60 °C to 220 °C **	 -60 °C to 400 °C **

\* Up to 180 °C in steam and hot water applications.  
 \*\* Maximum operating pressure: 25 bar.

PLUG DESIGN	
PARABOLIC	PARABOLIC (SOFT SEALING)
 <p> <b>Sealing:</b> Metal to metal  <b>Characteristic:</b> Equal percentage (EQP) or linear (PL)  <b>Flow direction:</b> From below  <b>Rangeability:</b> 50:1 (EQP) or 30:1 (PL)  <b>Leakage:</b> Class IV, acc. to IEC 60534-4                 </p>	 <p> <b>Sealing:</b> PTFE/GR  <b>Characteristic:</b> Equal percentage (EQP) or linear (PL)  <b>Flow direction:</b> From below  <b>Rangeability:</b> 50:1 (EQP) or 30:1 (PL)  <b>Leakage:</b> Class VI, acc. to IEC 60534-4  <b>Max. temp.:</b> 200 °C                 </p>

FLOW RATE COEFFICIENTS – PARABOLIC PL AND EQP PLUGS												
SIZE	Kvs (m <sup>3</sup> /h)											
	2,1	2,7	4	6,3	10	16	25	40	63	100	160	
DN 15	•	•	•									
DN 20	•	•	•	•								
DN 25	•	•	•	•	•							
DN 32			•	•	•	•						
DN 40				•	•	•	•					
DN 50					•	•	•	•				
DN 65						•	•	•	•			
DN 80							•	•	•	•		
DN 100								•	•	•	•	
SEAT Ø (mm)	12		15		19,2		25		32		38	
STROKE (mm)	20									30		

For conversion Kvs = Cv (US) x 0,865.

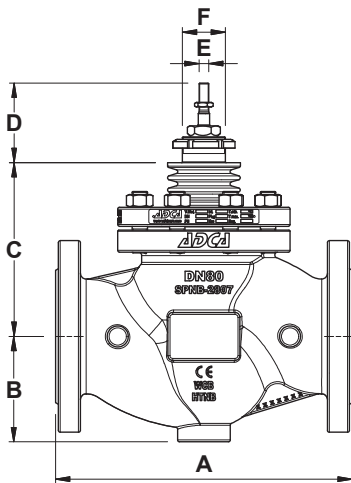

Valve with standard bonnet

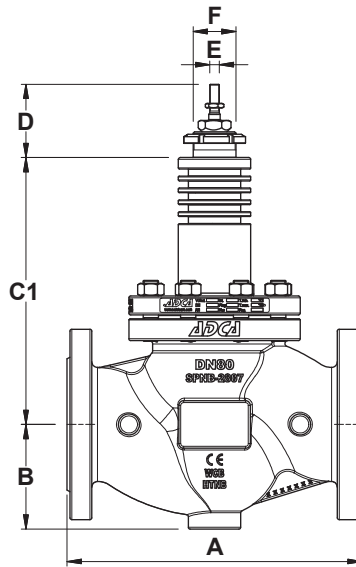

Valve with extended bonnet

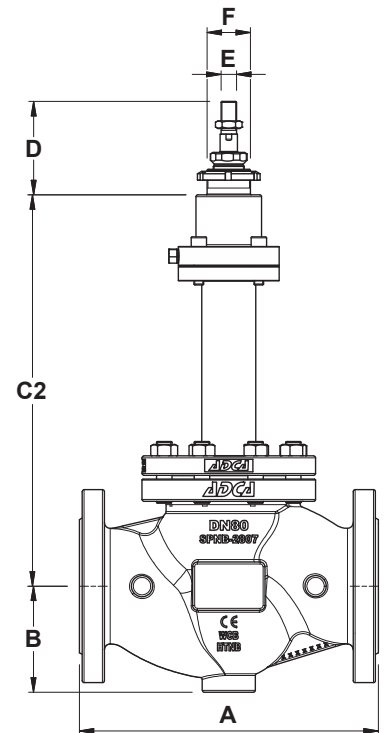

Bellows sealed valve

DIMENSIONS (mm)									
DIMENSION	SIZE								
	DN 15	DN 20	DN 25	DN 32	DN 40	DN 50	DN 65	DN 80	DN 100
A	130	150	160	180	200	230	290	310	350
B	52	53	58	70	75	85	100	110	130
C	104	104	109	109	113	125	176	182	194
C1	169	169	189	189	193	215	276	282	314
C2	271	271	271	271	271	275	365	371	373
D	77								
E	M10 x 1								
F	M40 x 1,5						M45 x 1,5		

Remark: Standard PN 16 DN 65 flanges are supplied with 4 holes. 8 holes, according to EN 1092-1/-2, on request.

WEIGHTS (kg)									
	SIZE								
	DN 15	DN 20	DN 25	DN 32	DN 40	DN 50	DN 65	DN 80	DN 100
STANDARD	5,1	6	6,9	10	12,6	16,4	31,8	38,2	50,6
EXTENDED	5,8	6,7	7,6	10,9	13,5	17,3	32,2	38,5	51,1
BELLOWS	7,8	8,7	9,5	12,6	15,3	18,8	32,6	38,7	51,6

MAX. PERMISSIBLE ACTUATING FORCES (kN)									
	SIZE								
	DN 15	DN 20	DN 25	DN 32	DN 40	DN 50	DN 65	DN 80	DN 100
MAX. FORCE	12								

### PA SERIES PNEUMATIC ACTUATORS

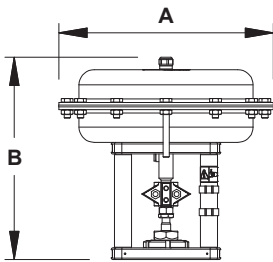

DIMENSIONS (mm)						
DIMENSION	PA10	PA206	PA281	PA341	PA436	PA80
A	170	209	275	336	430	405
B	251	236	243	323	291 / 311 *	505
WEIGHT (kg)	6,3	6,2	9,6	14,3	24,4 / 28 *	50,4

\* For actuators with spring ranges 1 - 2 bar; 1,5 - 3 bar and 2 - 4 bar.  
For more information, please consult IS 3.05 – PA Linear pneumatic actuators.

### EL SERIES ELECTRIC ACTUATORS

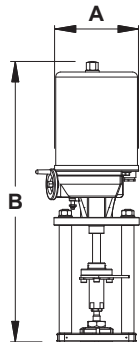

DIMENSIONS (mm)				
DIMENSION	EL12	EL20 – EL45	EL80 – EL120	EL250
A	129	148	188	216
B	333	485	587	683
WEIGHT (kg)	2,1	8	13	19

For more information, please consult IS 3.72 – EL Linear electric actuators.

### ELR SERIES ELECTRIC ACTUATORS

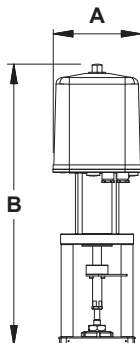

DIMENSIONS (mm)			
DIMENSION	ELR2.1	ELR2.2	ELR2.3
A	162	162	162
B	518 / 555 *	536 / 573 *	557 / 593 *
WEIGHT (kg)	8,7	9,3	10

\* With PEL electronic positioner.  
For more information, please consult IS 3.73 – ELR Linear electric actuators fail safe.

### AV SERIES ELECTRIC ACTUATORS

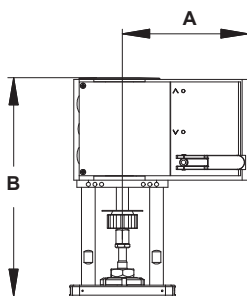

DIMENSIONS (mm)	
DIMENSION	AVM234S – AVF234S
A	166
B	289
WEIGHT (kg)	4,1

For more information, please consult IS 3.74 – AVM234S-AVF234S Linear electric actuators.

### MANUAL OPERATION HANDWHEEL

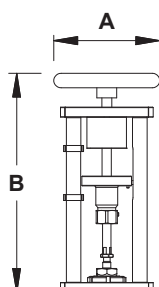

DIMENSIONS (mm)	
DIMENSION	MAH
A	160
B	331
WEIGHT (kg)	5,6

### MATERIALS

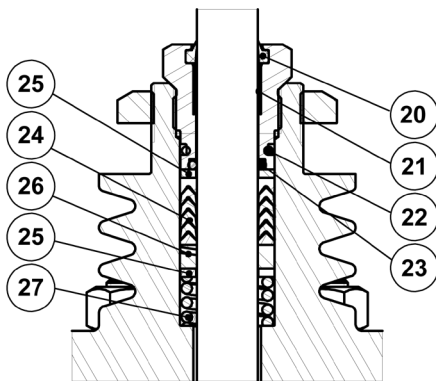
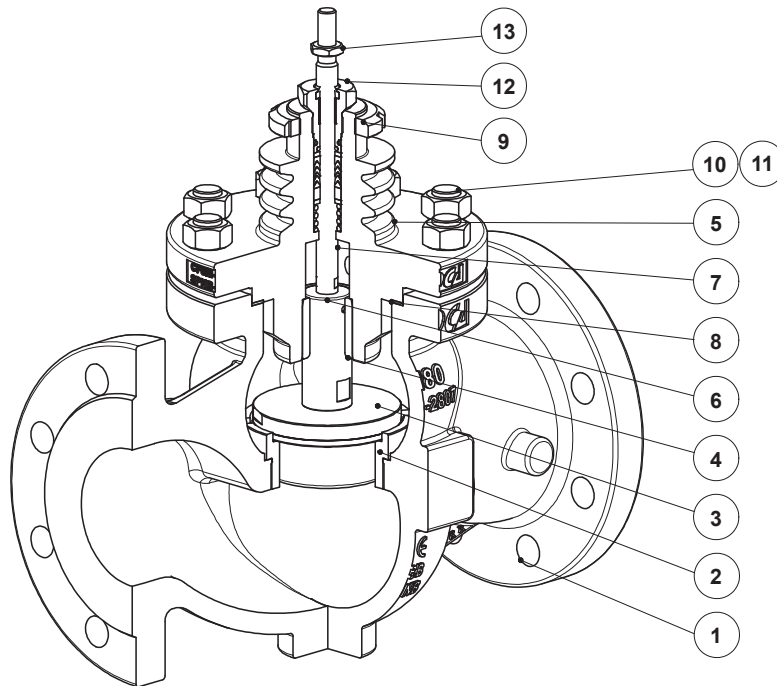

PTFE/GR V-RINGS  
 (V1.2)

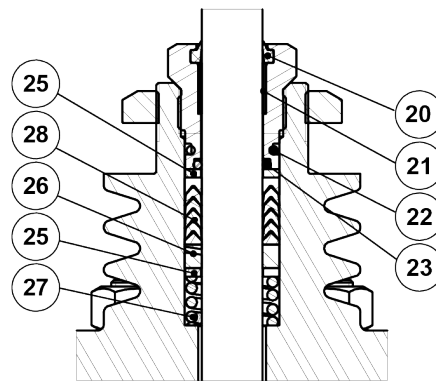

PTFE V-RINGS  
 (V2.2)

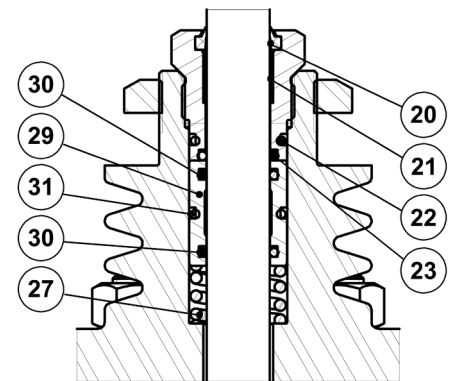

EPDM  
 (EP1)

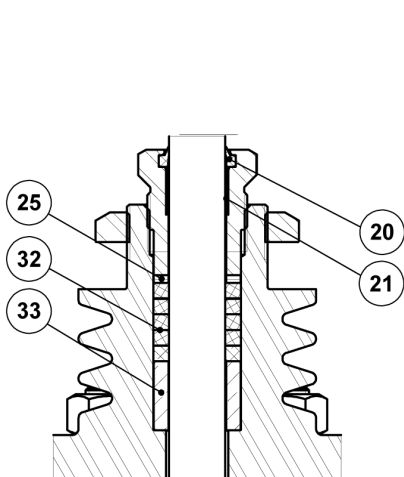

GRAPHITE  
 (G1)

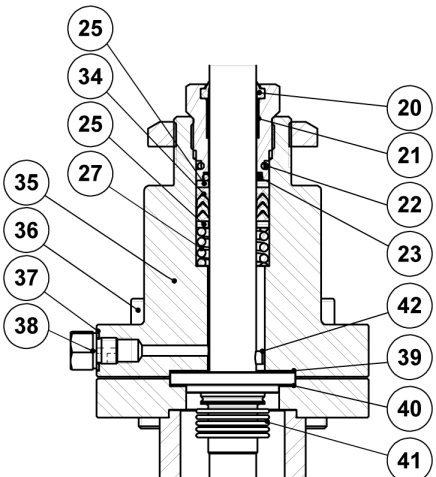

BELLOWS SEALING  
 (BV1)

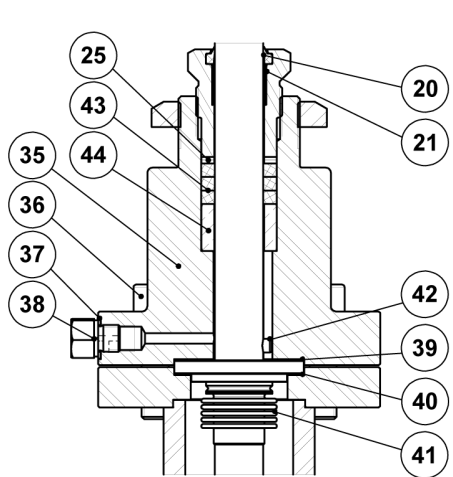

BELLOWS SEALING  
 (BG1)

**MATERIALS**

POS. N°	DESIGNATION	MATERIAL
1	Valve body (V16/2G)	GJS-400-15 / 0.7040
	Valve body (V16/2S)	A216 WCB / 1.0619
	Valve body (V16/2i)	A351 CF8M / 1.4408
2	* Seat	AISI 316L / 1.4404
3	* Valve plug	AISI 316L / 1.4404
4	Lower stem guide	Bronze CB1
5	Bonnet (V16/2G and V16/2S)	A351 CF8M / 1.4408 A216 WCB / 1.0619
	Bonnet (V16/2i)	A351 CF8M / 1.4408
6	* Post stem (DN 65 to DN 100)	AISI 316L / 1.4404
7	* Stem	AISI 316L / 1.4404
8	* Gasket	Stainless steel / Graphite
9	Lock nut	A351 CF8 / 1.4308
10	Nuts (V16/2G and V16/2S)	Steel 8.8
	Nuts (V16/2i)	Stainless steel A2-70
11	Studs (V16/2G and V16/2S)	34CrNiMo6 / 1.6582
	Studs (V16/2i)	Stainless steel A2-70
12	* Packing nut	AISI 303 / 1.4305
13	Lock nut	AISI 304 / 4.4301
20	* Scraper ring	Viton
21	* Plain bearing	Bronze / PTFE
22	* O-ring	EPDM
23	* O-ring	Viton
24	* Chevron packing set	PTFE ; Graphite filled PTFE
25	Washer	AISI 304 / 1.4301
26	* Stem guide	Stainless steel filled PTFE
27	* Spring	AISI 302 / 1.4310
28	* Chevron packing set	PTFE
29	O-ring guide	AISI 304 / 1.4301
30	* O-ring	EPDM
31	* O-ring	EPDM
32	* Packing set	Expanded graphite
33	Packing spacer	AISI 304 / 1.4301
34	* Safety packing set	Graphite filled PTFE
35	Bellows bonnet	AISI 316L / 1.4404
36	Bolts	Stainless steel A2-70
37	Gasket	Copper
38	Compression fitting	AISI 316 / 1.4401
39	* Gasket	Stainless steel / Graphite
40	* Gasket	Stainless steel / Graphite
41	* Metal bellows	AISI 316Ti / 1.4571
42	* Locking pin	AISI 303 / 1.4305
43	* Safety packing set	Expanded graphite
44	Packing spacer	AISI 304 / 1.4301

\* Available spare parts.

ORDERING CODES V16/2 a)													
Valve model	V1	2	G	S	1	U	1	1	1	E	FD	L	015
Globe control valve, two-way, straight body	V1												
Valve series													
Series 2		2											
Body material													
GJS-400-15 / 0.7040 SG iron			G										
A216 WCB / 1.0619 carbon steel			S										
A351 CF8M / 1.4408 stainless steel			I										
Bonnet design													
Standard				S									
Extended				E									
Trim design													
Unbalanced trim					1								
Flow direction													
Flow under the plug						U							
Flow over the plug						O							
Stem sealing													
PTFE/GR V-Rings (V1.2)							1						
Virgin PTFE V-Rings (V2.2)							2						
Graphite (G1)							3						
EPDM (EP1)							4						
Stainless steel bellows with PTFE/GR safety packing (BV1)							8						
Stainless steel bellows with graphite safety packing (BG1)							9						
Plug design													
Parabolic								1					
Valve sealing													
Metal to metal (class IV)									1				
Soft sealed with PTFE/GR (class VI)										3			
Stellited (class IV)											4		
Characteristic													
Equal percentage (EQP)										E			
Linear (PL)										L			
Flow rate coefficient													
Kvs 4											FD		
See table below for other Kvs value codes													
Pipe connection													
Flanged EN 1092-1/-2 PN 16												L	
Flanged EN 1092-1 PN 40												N	
Size													
DN 15													015
DN 20													020
...													
Special valves / Extras													
Full description or additional codes have to be added in case of a non-standard combination													E

a) Codification for valve only. For actuator codes, refer to the appropriate information sheet.

FLOW RATE COEFFICIENT CODES											
Kvs	2,1	2,7	4	6,3	10	16	25	40	63	100	160
Code	R2	R1	FD	FE	FF	FG	FH	FI	FJ	FL	FM

## TWO-WAY GLOBE CONTROL VALVES V16/2 (ASME)

### DESCRIPTION

The ADCATrol V16/2 is a series of single seated, two-way globe control valves designed for simple process engineering and industrial applications with non-critical operating conditions. These valves can be assembled with pneumatic, hydraulic or electric actuators, for modulating and shut-off control tasks.

### MAIN FEATURES

Compact and cost-effective.  
Modular design to meet process requirements.  
Stem guided (up to 2") and post guided (from 3" to 4").  
Parabolic plug design.  
Stainless steel trim.



### OPTIONS AND ACCESSORIES:

- Bonnet extension for high and low temperatures.
- Various stem sealing options including bellows sealing.
- Soft or stellite valve sealing.
- Reduced bore trims.
- Silencers.

**USE:** Saturated and superheated steam.  
Hot and superheated water.  
Air, gases and others.

**AVAILABLE MODELS:** V16/2S – carbon steel.

**SIZES:** 1/2" to 4".

**CONNECTIONS:** Flanged ASME B16.5 Class 150 or 300.

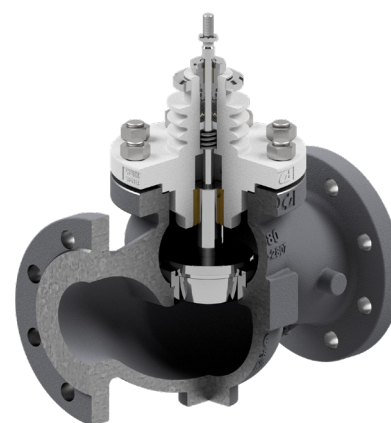

### CE MARKING – GROUP 2 (PED – European Directive)



Class 150	Class 300	Category
1/2" to 2"	1/2" to 1"	SEP
3" to 4"	1 1/2" to 4"	1 (CE marked)

### BODY LIMITING CONDITIONS \*

CLASS 150		CLASS 300	
ALLOWABLE PRESSURE	RELATED TEMPERATURE	ALLOWABLE PRESSURE	RELATED TEMPERATURE
19,3 bar	-10 °C / 50 °C	50 bar	-10 °C / 50 °C
15,8 bar	150 °C	43,9 bar	200 °C
12,1 bar	250 °C	36,9 bar	350 °C
8,4 bar	350 °C	34,6 bar	400 °C

\* Rating according to EN 1759-1:2004.



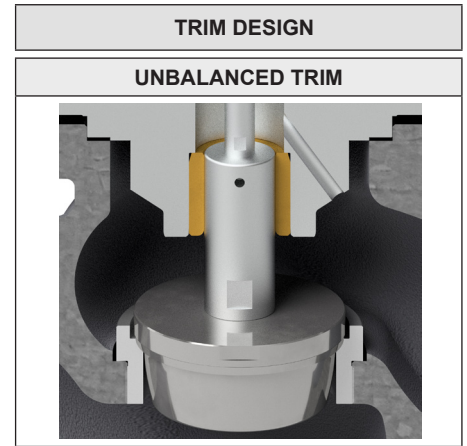

BONNET DESIGN	
STANDARD	EXTENDED
 -10 °C to 250 °C	 Above 250 °C

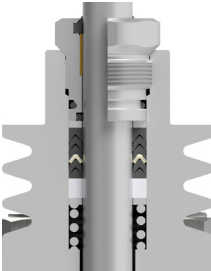
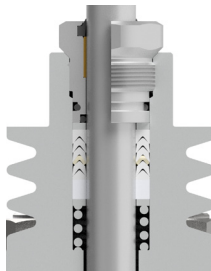
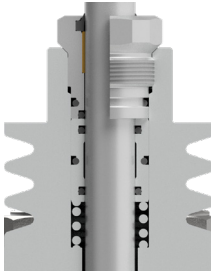
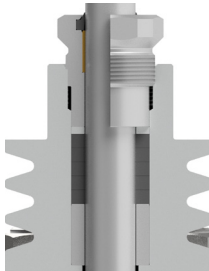
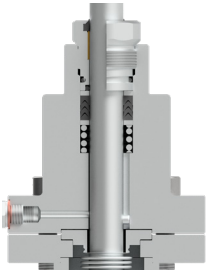
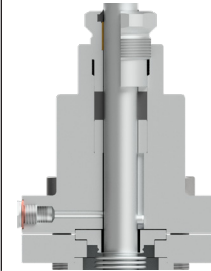

STEM SEALING					
PTFE/GR V-RINGS (V1.2)	PTFE V-RINGS (V2.2)	EPDM (EP1)	GRAPHITE (G1)	BELLOWS	
				(BV1)	(BG1)
 -10 °C to 220 °C	 -10 °C to 180 °C	 -10 °C to 150 °C *	 -10 °C to 400 °C	 -60 °C to 220 °C **	 -60 °C to 400 °C **

\* Up to 180 °C in steam and hot water applications.

\*\* Maximum operating pressure: 25 bar.

PLUG DESIGN	
PARABOLIC	PARABOLIC (SOFT SEALING)
 <p> <b>Sealing:</b> Metal to metal  <b>Characteristic:</b> Equal percentage (EQP) or linear (PL)  <b>Flow direction:</b> From below  <b>Rangeability:</b> 50:1 (EQP) or 30:1 (PL)  <b>Leakage:</b> Class IV, acc. to IEC 60534-4         </p>	 <p> <b>Sealing:</b> PTFE/GR  <b>Characteristic:</b> Equal percentage (EQP) or linear (PL)  <b>Flow direction:</b> From below  <b>Rangeability:</b> 50:1 (EQP) or 30:1 (PL)  <b>Leakage:</b> Class VI, acc. to IEC 60534-4  <b>Max. temp.:</b> 200 °C         </p>

FLOW RATE COEFFICIENTS – PARABOLIC PL AND EQP PLUGS												
SIZE	Kvs (m³/h)											
	2,1	2,7	4	6,3	10	16	25	40	63	100	160	
1/2"	•	•	•									
3/4"	•	•	•	•								
1"	•	•	•	•	•							
1 1/2"				•	•	•	•					
2"					•	•	•	•				
3"							•	•	•	•		
4"								•	•	•	•	
SEAT Ø (mm)	12		15	19,2	25	32	38	48	65	76	96	
STROKE (mm)	20								30			

For conversion  $Kvs = Cv (US) \times 0,865$ .

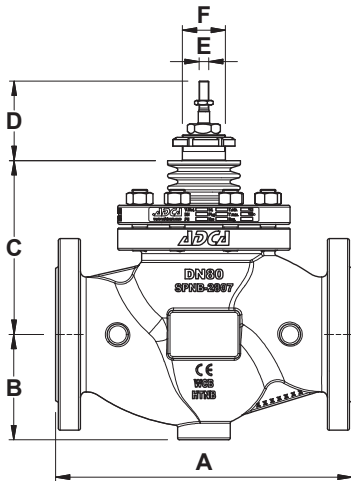

Valve with standard bonnet

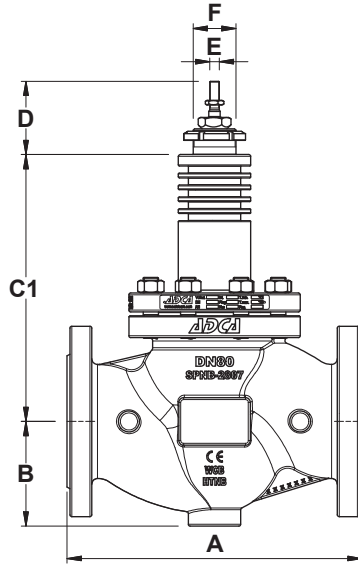

Valve with extended bonnet

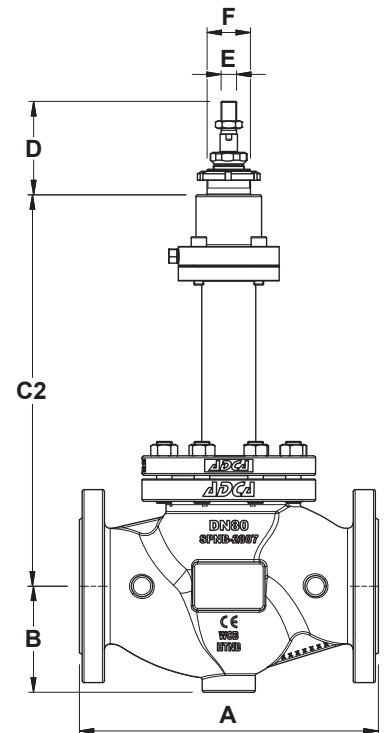

Bellows sealed valve

DIMENSIONS (mm)									
DIMENSION		SIZE							
		1/2"	3/4"	1"	1 1/2"	2"	3"	4"	
A	CLASS 150	184 a)	184 a)	184	235	267	318	368	
	CLASS 300	190 a)	194 a)	197	235	267	318	368	
B	CLASS 150	44,5	49	54	65	85	110	130	
	CLASS 300	47,5	58,5	62	78	85	110	130	
C		85	85	90	115	125	175	190	
C1		150	150	170	195	215	275	310	
C2		290	290	295	285	285	392	400	
D		77							
E		M10 x 1							
F		M40 x 1,5					M45 x 1,5		

a) With welded-on flanges.

WEIGHTS (kg)								
		SIZE						
		1/2"	3/4"	1"	1 1/2"	2"	3"	4"
STANDARD	CLASS 150	4,5	5	6,9	12,1	16,8	38,3	54,2
	CLASS 300	4,9	6	7,5	13,9	17,5	40,3	58,5
EXTENDED	CLASS 150	5,2	5,7	7,6	13	17,7	38,6	54,7
	CLASS 300	5,6	6,7	8,2	14,8	18,4	40,6	59
BELLOWS	CLASS 150	7,2	7,7	9,5	14,8	19,2	38,8	55,2
	CLASS 300	7,6	8,7	10,1	16,6	19,9	40,8	59,5

MAX. PERMISSIBLE ACTUATING FORCES (kN)								
		SIZE						
		1/2"	3/4"	1"	1 1/2"	2"	3"	4"
MAX. FORCE		12						

### PA SERIES PNEUMATIC ACTUATORS

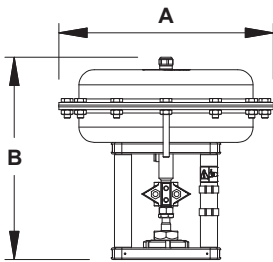

DIMENSIONS (mm)						
DIMENSION	PA10	PA206	PA281	PA341	PA436	PA80
A	170	209	275	336	430	405
B	251	236	243	323	291 / 311 *	505
WEIGHT (kg)	6,3	6,2	9,6	14,3	24,4 / 28 *	50,4

\* For actuators with spring ranges 1 - 2 bar; 1,5 - 3 bar and 2 - 4 bar.  
For more information, please consult IS 3.05 – PA Linear pneumatic actuators.

### EL SERIES ELECTRIC ACTUATORS

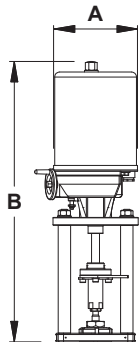

DIMENSIONS (mm)				
DIMENSION	EL12	EL20 – EL45	EL80 – EL120	EL250
A	129	148	188	216
B	333	485	587	683
WEIGHT (kg)	2,1	8	13	19

For more information, please consult IS 3.72 – EL Linear electric actuators.

### ELR SERIES ELECTRIC ACTUATORS

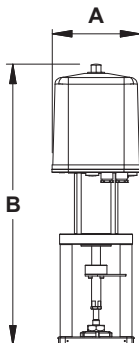

DIMENSIONS (mm)			
DIMENSION	ELR2.1	ELR2.2	ELR2.3
A	162	162	162
B	518 / 555 *	536 / 573 *	557 / 593 *
WEIGHT (kg)	8,7	9,3	10

\* With PEL electronic positioner.  
For more information, please consult IS 3.73 – ELR Linear electric actuators fail safe.

### AV SERIES ELECTRIC ACTUATORS

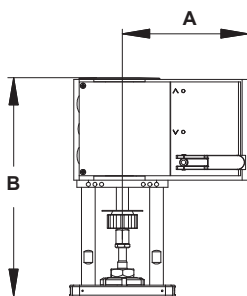

DIMENSIONS (mm)	
DIMENSION	AVM234S – AVF234S
A	166
B	289
WEIGHT (kg)	4,1

For more information, please consult IS 3.74 – AVM234S-AVF234S Linear electric actuators.

### MANUAL OPERATION HANDWHEEL

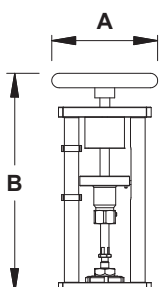

DIMENSIONS (mm)	
DIMENSION	MAH
A	160
B	331
WEIGHT (kg)	5,6

**MATERIALS**

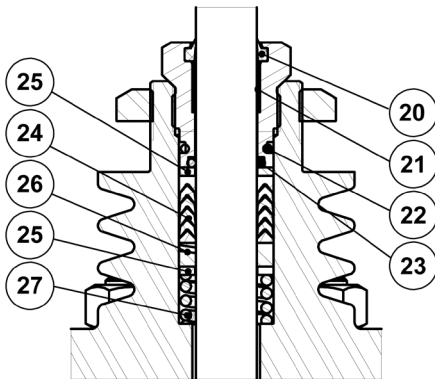
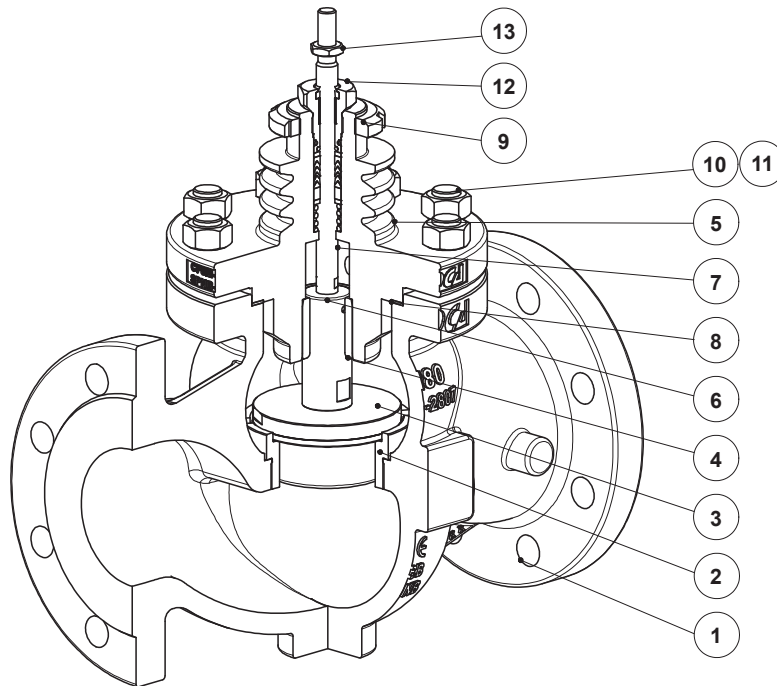

**PTFE/GR V-RINGS  
 (V1.2)**

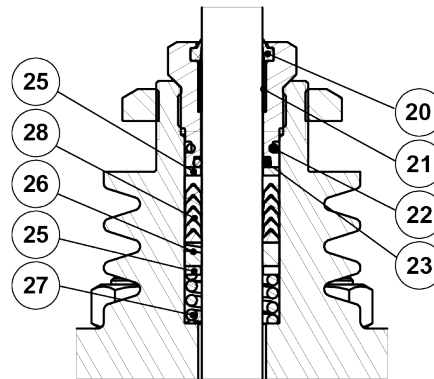

**PTFE V-RINGS  
 (V2.2)**

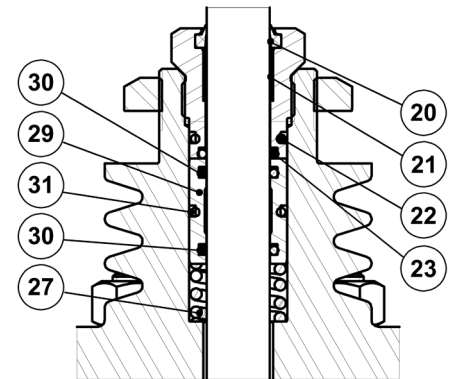

**EPDM  
 (EP1)**

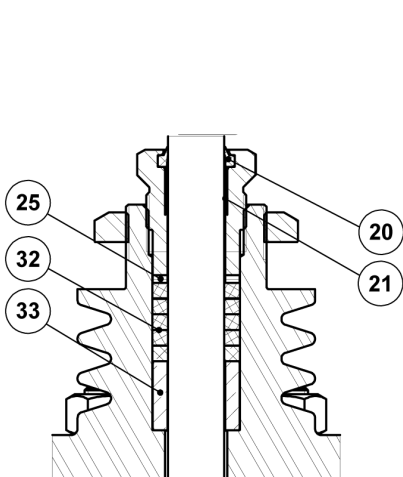

**GRAPHITE  
 (G1)**

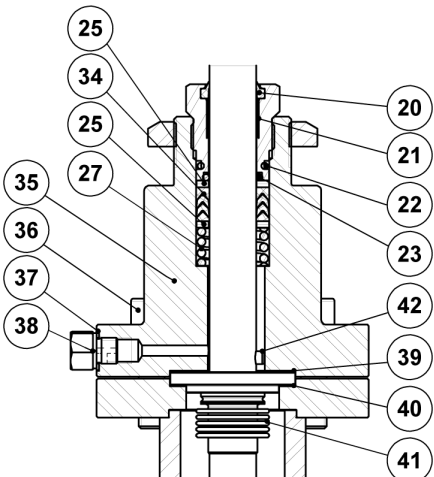

**BELLOWS SEALING  
 (BV1)**

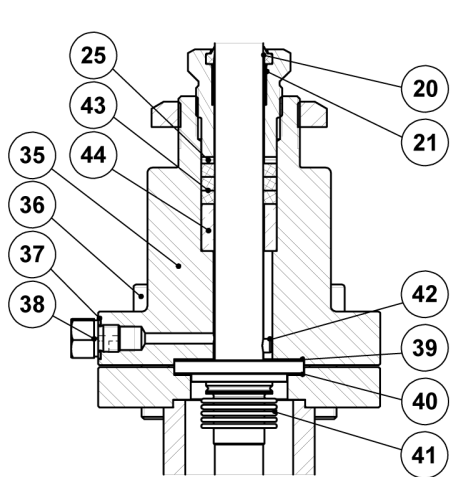

**BELLOWS SEALING  
 (BG1)**

MATERIALS		
POS. N°	DESIGNATION	MATERIAL
1	Valve body	A216 WCB / 1.0619
2	* Seat	AISI 316L / 1.4404
3	* Valve plug	AISI 316L / 1.4404
4	Lower stem guide	Bronze CB1
5	Bonnet	A351 CF8M / 1.4408 A216 WCB / 1.0619
6	* Post stem (3" to 4")	AISI 316L / 1.4404
7	* Stem	AISI 316L / 1.4404
8	* Gasket	Stainless steel / Graphite
9	Lock nut	A351 CF8 / 1.4308
10	Nuts	Steel 8.8
11	Studs	34CrNiMo6 / 1.6582
12	* Packing nut	AISI 303 / 1.4305
13	Lock nut	AISI 304 / 4.4301
20	* Scraper ring	Viton
21	* Plain bearing	Bronze / PTFE
22	* O-ring	EPDM
23	* O-ring	Viton
24	* Chevron packing set	PTFE; Graphite filled PTFE
25	Washer	AISI 304 / 1.4301
26	* Stem guide	Stainless steel filled PTFE
27	* Spring	AISI 302 / 1.4310
28	* Chevron packing set	PTFE
29	O-ring guide	AISI 304 / 1.4301
30	* O-ring	EPDM
31	* O-ring	EPDM
32	* Packing set	Expanded graphite
33	Packing spacer	AISI 304 / 1.4301
34	* Safety packing set	Graphite filled PTFE
35	Bellows bonnet	AISI 316L / 1.4404
36	Bolts	Stainless steel A2-70
37	Gasket	Copper
38	Compression fitting	AISI 316 / 1.4401
39	* Gasket	Stainless steel / Graphite
40	* Gasket	Stainless steel / Graphite
41	* Metal bellows	AISI 316Ti / 1.4571
42	* Locking pin	AISI 303 / 1.4305
43	* Safety packing set	Expanded graphite
44	Packing spacer	AISI 304 / 1.4301

\* Available spare parts.

ORDERING CODES V16/2 a)													
Valve model	V1	2	S	S	1	U	1	1	1	E	FD	U	015
Globe control valve, two-way, straight body	V1												
<b>Valve series</b>													
Series 2		2											
<b>Body material</b>													
A216 WCB / 1.0619 carbon steel			S										
<b>Bonnet design</b>													
Standard				S									
Extended				E									
<b>Trim design</b>													
Unbalanced trim					1								
<b>Flow direction</b>													
Flow under the plug						U							
Flow over the plug						O							
<b>Stem sealing</b>													
PTFE/GR V-Rings (V1.2)									1				
Virgin PTFE V-Rings (V2.2)									2				
Graphite (G1)									3				
EPDM (EP1)									4				
Stainless steel bellows with PTFE/GR safety packing (BV1)									8				
Stainless steel bellows with graphite safety packing (BG1)									9				
<b>Plug design</b>													
Parabolic										1			
<b>Valve sealing</b>													
Metal to metal (class IV)											1		
Soft sealed with PTFE/GR (class VI)												3	
Stellited (class IV)													4
<b>Characteristic</b>													
Equal percentage (EQP)												E	
Linear (PL)												L	
<b>Flow rate coefficient</b>													
Kvs 4												FD	
See table below for other Kvs value codes													
<b>Pipe connection</b>													
Flanged ASME B16.5 Class 150													U
Flanged ASME B16.5 Class 300													V
<b>Size</b>													
1/2"													015
3/4"													020
...													
<b>Special valves / Extras</b>													
Full description or additional codes have to be added in case of a non-standard combination													
E													

a) Codification for valve only. For actuator codes, refer to the appropriate information sheet.

FLOW RATE COEFFICIENT CODES											
Kvs	2,1	2,7	4	6,3	10	16	25	40	63	100	160
Code	R2	R1	FD	FE	FF	FG	FH	FI	FJ	FL	FM