

CAST STEEL PIPELINE T STRAINERS IS40T DN15 to DN100 (EN)

DESCRIPTION

IS40T cast steel T strainers are applicable to all types of steam, water, oil and air systems.

Their purpose is to protect steam traps, regulating valves, pressure reducing valves, piping, etc. from dirt which are often times the cause of damage and consequently energy loss of fluid systems.

Connections are flanged.

OPTIONS: Different screen aperture sizes
Drain plug or drain valve in strainer cap

USE: Saturated steam, water, oil, air and other compatible fluids.

AVAILABLE MODELS: IS40TS – Carbon steel
IS40TI – Stainless steel

SIZES: DN 15 to DN 100

SCREENS: 0,5 mm aperture up to DN 25
1,5 mm aperture from DN 32 to DN 80
2 mm aperture DN 100

CONNECTIONS: Flanged EN 1092-1 PN40

INSTALLATION: Horizontal or vertical installation.

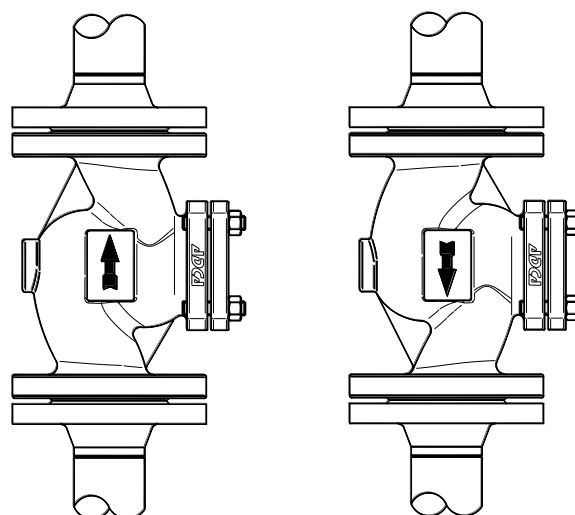
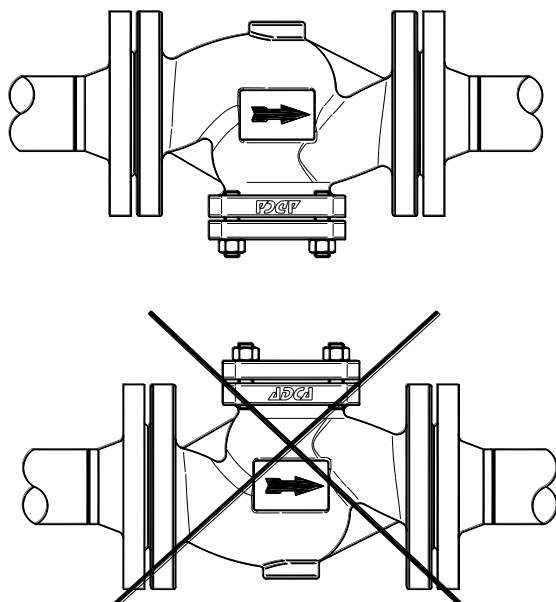

CE MARKING (PED - European Directive 97/23/EC)			
PN 16	PN 25	PN 40	Category
DN15 to DN50	DN15 to DN40	DN15 to DN32	SEP - art. 3, paragraph3
DN65 to DN100	DN50 to DN100	DN40 to DN100	1 (CE Marked)

VALVE BODY LIMITING CONDITIONS

IS40TS - PN16 *		IS40TS - PN25 *		IS40TS - PN40 *		IS40TI - PN40 *	
ALLOWABLE PRESSURES	RELATED TEMP.	ALLOWABLE PRESSURES	RELATED TEMP.	ALLOWABLE PRESSURES	RELATED TEMP.	ALLOWABLE PRESSURES	RELATED TEMP.
16 bar	-10 /120° C	25 bar	-10 /50° C	40 bar	-10 /50° C	40 bar	-10 /50° C
13,3 bar	200 °C	20,8 bar	200 °C	33,3 bar	200 °C	33,7 bar	200 °C
12,1 bar	250 °C	19 bar	250 °C	27,6 bar	300 °C	29,7 bar	300 °C
11 bar	300 °C	17,2 bar	300 °C	25,7 bar	350 °C	28,5 bar	350 °C
10,2 bar	350 °C	16 bar	350 °C	23,8 bar	400 °C	27,4 bar	400 °C

- Rating according to EN1092-1:2007

MATERIALS

POS.	DESIGNATION	MATERIAL IS40TS	MATERIAL IS40TI
1	Body	ASTM A216WCB/1.0619; GP240GH / 1.0619	CF8M / 1.4408
2	Centering ring	AISI304 / 1.4301	AISI304 / 1.4301
3	Cover	AISI304 / 1.4301	AISI304 / 1.4301
4	*Gasket	St.Steel / Graphite	St.Steel / Graphite
5	*Screen	AISI304 / 1.4301	AISI304 / 1.4301
6	Studs	Steel	A2 - 70
7	Nuts	Steel	A2 - 70

* Available spare parts

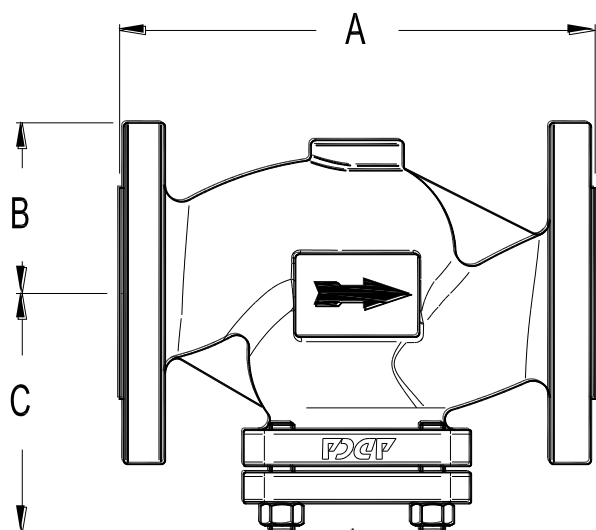
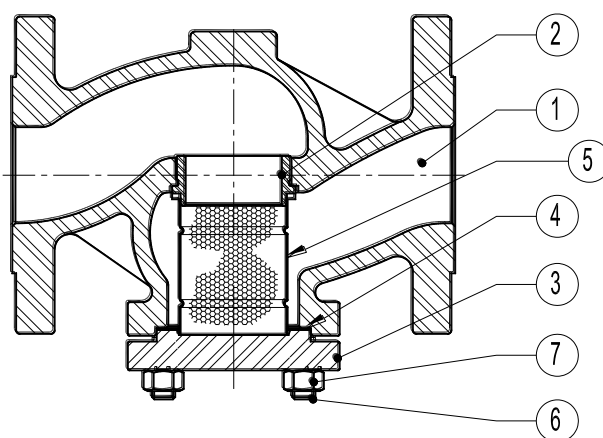

DIMENSIONS (mm)					
SIZE DN	A	B	C	G *	WGT. Kgs
15	130	48	80	1/2"	3,7
20	150	53	80	1/2"	4,2
25	160	58	80	1/2"	5,3
32	180	70	100	1/2"	7,8
40	200	75	105	1/2"	9,6
50	230	83	115	1/2"	14
65	290	93	155	1/2"	23,5
80	310	100	155	1/2"	27,9
100	350	118	165	1/2"	34,6

* Other on request

