

STEAM - WATER MIXERS ADCAMIX MX20

DESCRIPTION

The steam/water Adcamix mixers provide cheap, instant source of low pressure hot water by using existing steam and cold water supplies.

The mixer incorporates a safety device to ensure that live steam cannot be accidentally ejected, even if for some reason the cold water supply fails.

The temperature of water at the outlet of the Adcamix is easily controlled by using water and steam valves fitted to the inlets.

Connections are female screwed.

MAIN FEATURES

Safety device against accidentally steam ejection.

Non return valves included.

Complete stainless steel construction.

Quiet operation.

OPTIONS:

Alternative steam valve if live steam is required, e.g. for sterilisation.

ACCESSORIES:

Stainless steel pedestal.
Adjustable spray gun.
Couple of steam/water valves.
Hot water/steam hose.
Stainless suspension for hose.

USE :

Saturated steam and cold water.

AVAILABLE MODELS :

MX 20.

SIZES :

3/4" x 3/4".

CONNECTIONS :

Female screwed ISO 7/1Rp (BS21).

INSTALLATION :

Vertical wall installation.
See IMI installation and maintenance instructions.



FLOW RATE CAPACITY - HOT WATER FLOW l/h								
STEAM PRESSURE	HOT WATER OUTLET TEMPERATURE							
	bar	40°C	50°C	60°C	70°C	80°C	90°C	95°C
2,5	1900	1400	1150	900	700	650	600	
3	2250	1600	1230	1030	900	800	700	
4	2700	2000	1550	1250	1000	850	800	
5	3250	2300	1800	1500	1250	900	850	
6	3900	2900	2250	1800	1500	1200	1100	
7	4200	3100	2400	1950	1600	1300	1200	
8	4800	3500	2700	2100	1800	1550	1280	
9	5200	3900	3000	2450	2000	1700	1600	
10	5900	4100	3250	2700	2250	1900	1750	

APPLICATION LIMITS	
Minimum steam pressure	2,5 bar
Maximum steam pressure	10 bar
Steam pressure equal to or no more than 3 times the water pressure.	
Water pressure must not be higher than steam pressure.	

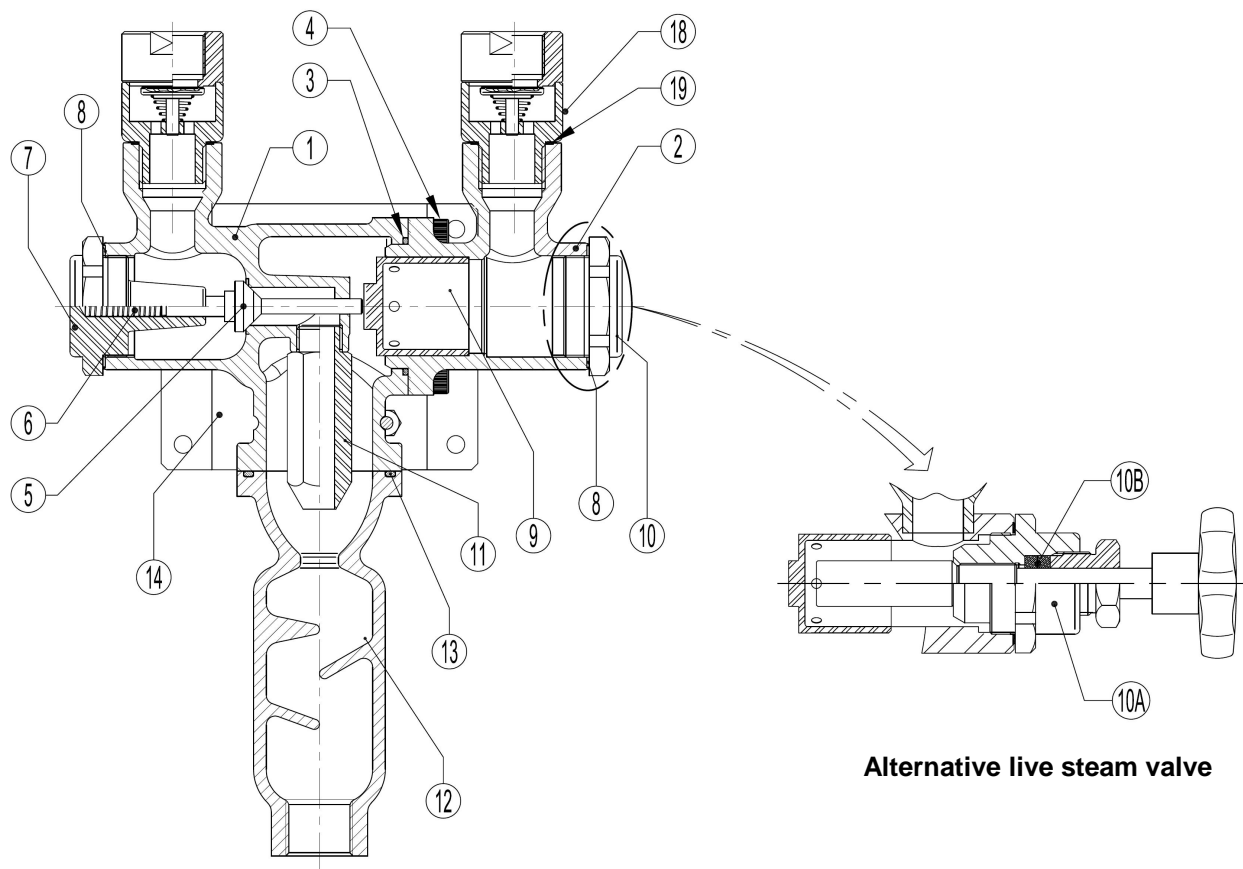

Alternative live steam valve

MATERIALS		
POS.	DESIGNATION	MATERIAL
1	Steam body	CF8M / 1.4408
2	Water body	CF8M / 1.4408
3	* Gasket	NBR
4	Bolts	A2-70
5	* Steam valve	St.St./Graphite
6	* Valve spring	AISI 302 / 1.4300
7	Steam cover	AISI 316 / 1.4401
8	* Gasket	PTFE
9	* Piston	AISI 316 / 1.4401
10	Water cover	AISI 316 / 1.4401
10A	Steam valve	AISI 316 / 1.4401
10B	* Paking	PTFE
11	Steam nozzle	AISI 316 / 1.4401
12	Mixing chamber	CF8M / 1.4408
13	* Gasket	VITON
14	Support	AISI 304 / 1.4301
18	* Check valve	AISI 316 / 1.4401
19	* Gasket	PTFE

*Available spare parts

VALVE DIMENSIONS (mm)

DN	A	B	C	D	E	Wgt Kg
3/4"	135	220	110	57,5	330	5,3

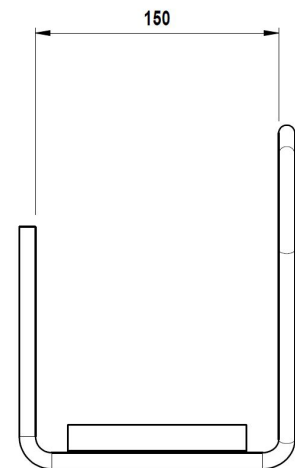
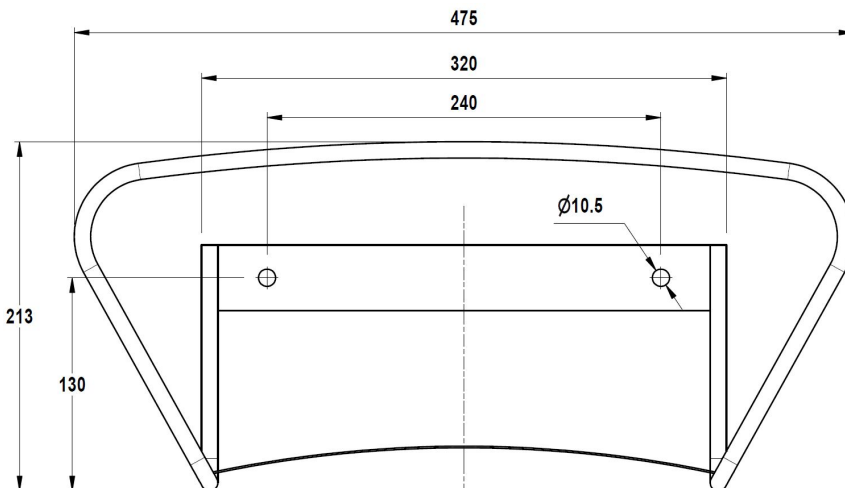
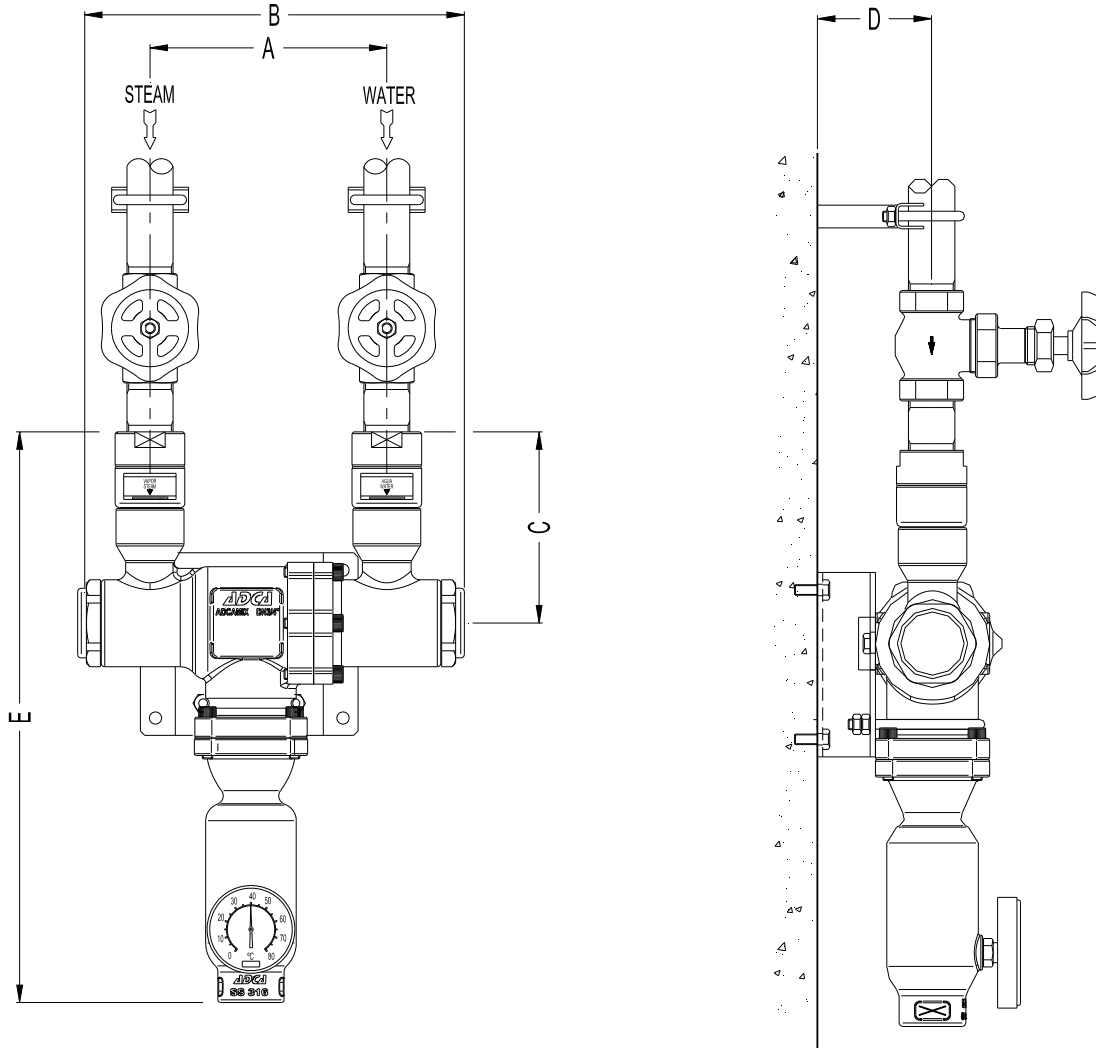

Stainless steel suspension for hose

VALSTEAM ADCA

We reserve the right to change the design and material of this product without notice.