

Electrode based electronic level controller

For steam boilers

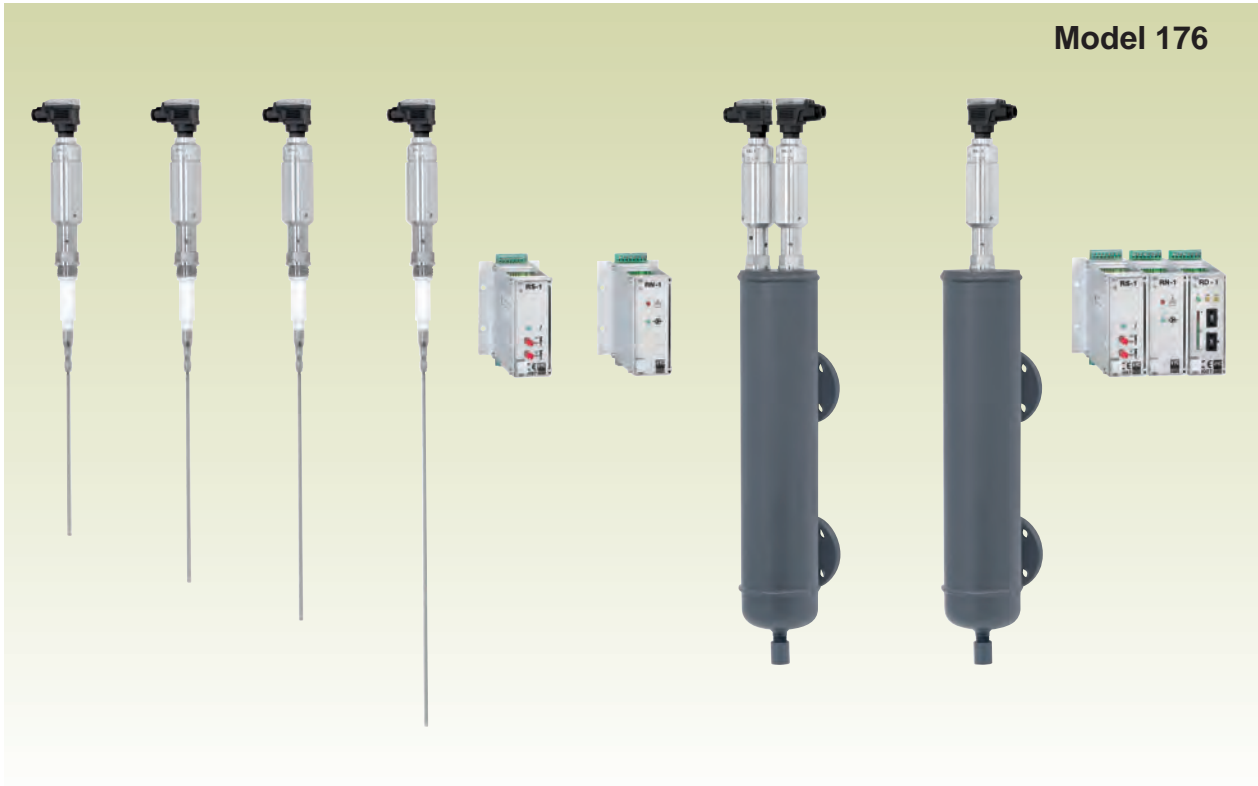

Model 176



EN ASME/MNPT

This device guarantees a safe and reliable control, regulation and electronic signalling of the level of electrically conducting liquids in; steam and hot water boilers, autoclaves, preheaters, pressure vessels, feedwater and condensates tanks, processes, etc.

In accordance with the requirements of directive 97/23/EC.

EC controller verification certified by: TÜV Internacional Grupo TÜV Rheinland, S.L. EC 0035.

Type (Module D) EC examination report nº DP B EPR 0535132967, DP B EPR 0535132963 certified by: TÜV Internacional Grupo TÜV Rheinland, S.L.

Conforms to the low voltage directive 73/23/CE version 93/68/CE.

According to the electromagnetic compatibility directive 89/336/CE version 93/68/CE.

Specifications

- The electrode design is technically perfect, being fully tightness in steam, with several sealing points.
- Simplicity of construction, eliminating the need for moving mechanical parts, which leads to minimum maintenance.
- Materials carefully selected for their resistance to wear, temperature and pressure conditions.
- Due to solid construction the electrodes can operate in critical temperature and corrosion.
- Ease of connection and adjustment of operating points. Being a fixed installation greatly inhibits any type of manipulation.
- High reliability and safety which allows operation of steam boilers without permanent supervision.
- Through the elimination of unnecessary equipment and the direct installation of the electrode in the boiler body a maintenance free installation is obtained, with the corresponding financial savings.
- Centralized control and possibility of executing complex regulation and control.
- All controllers and electrodes are rigorously tested and verified.
- Each of the components is numbered, registered and checked. If prior request is made a certificates of materials, batch and tests will be supplied.

Level controller. RN-1

Level electrode. EN-1

An RN-1 level controller together with two EN-1 level electrodes controls the operation of the boiler feedwater pumps, and consequently the level of the water in the boiler.

In installations without constant preventative maintenance we recommend the installation of a third EN-1 level electrode, associated with the same RN-1 level controller, whose function is to cut-off the feedwater pump if the maximum allowed level in the boiler is exceeded.

Operating principles

The operation of the RN-1 level controller is based on the measurement by conductivity principle. When the probe of the EN-1 level electrode is submerged or out of the water, the bridging circuit of the switching amplifier is made or broken respectively. The signal is amplified and is used to energize a relay.

The circuits for water level control and maximum water level are symmetrical and totally separated. The switching relays of each circuit are independent, but with a common power supply.

In order to avoid disturbances to the control system caused by waves in the boiler water, the power signals from the RN-1 level controller have a built in 10 second delay. This means that the motors and connection elements are protected from spurious interruptions.

Operation

When the level of water falls below the normal operating level, the probe of the EN-1.2 level electrode (feedwater pump stop) is exposed followed by that of the EN-1.3 (feedwater pump start). Automatically, the RN-1 level controller switching relay is energized and the feedwater pump is started. The green lamp, which indicates that the feedwater pump is running, is lit up. The probe of the EN-1.3 level electrode (feedwater pump start) is gradually submerged along with that of EN-1.2 (feedwater pump stop). When the EN-1.2 level electrode probe (feedwater pump stop) is submerged the switching relay is deenergised, the green lamp switched off, and the pump shut down. If, due to failure, the pump continues running until the EN-1.1 level electrode probe is submerged (maximum level) the second switching relay on the RN-1 level controller is energized, the red lamp indicating maximum level is lit up, and the feedwater pump is disconnected.

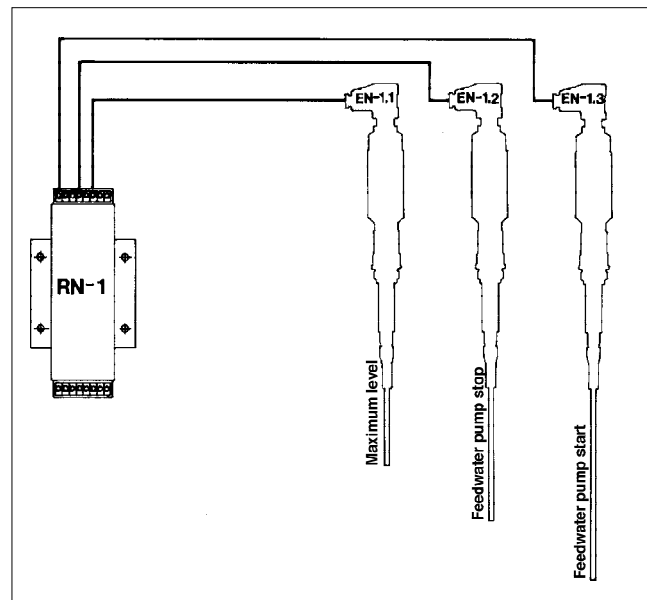

Maintenance

The RN-1 level controller does not require daily checking. However a functional check should be carried out periodically. Check the electrode probe every six months and clean thoroughly.

After every change of controllers or electrodes, the correct operation of the controls should be checked before putting the boiler in service.

Breakdown

1- The feedwater pump does not start and the RS-1 minimum level safety controller indicates insufficient water:

- Check the state of the thermal protection relay on the feedwater pump motor.
- Check the supply voltages on the RN-1 level controller.
- Check the connections between controller and electrode (RN-1 / EN-1.3).
- Check the RN-1 level controller fuse (M.250/0,10A).
- The probe on the EN-1.3 level electrode for feedwater pump start-up is too long.
- The probe on the EN-1.2 level electrode for feedwater pump stop is not earthed.
- Change the RN-1 level controller.

2- The feedwater pump does not stop and the boiler is over-filled:

- Check the controller-electrode connections (RN-1/EN-1.2).
- The probe on the EN-1.2 level electrode for feedwater pump stop is too short.
- Change the RN-1 level controller.

VYC controllers and electrodes are officially approved by several international organisations and must be repaired only in our workshops.

Minimum level safety controller. RS-1

Minimum level safety electrode. ES-1

The RS-1 minimum level safety controller, together with the ES-1 minimum level safety electrode, facilitates the measurement of minimum water level in the boiler.

If a minimum level is detected, the failure signal is automatically activated and the burner is disconnected. The controller and the electrode are equipped with devices for selfchecking and manual checking, which ensures reliable and safe operation. Any number of RS-1 minimum level safety controllers, each with its own ES-1 minimum level safety electrode, can be installed to obtain the required level of protection.

Operating principles

The operation of the RS-1 minimum level safety controller is based on the difference in conductivity of water and steam. The ES-1 minimum level safety electrode consists of a water measuring probe and a steam compensating ring. These are concentrically mounted and separated by special insulating covers. When the water measuring probe is out of the water the bridging circuit in the switching amplifier is lost. The signal is amplified and desenergizes a relay which activates the failure signal and disconnects the burner.

The RS-1 minimum level safety controller has two channels and is equipped with a self-checking device. At a given switching frequency, the device carries out a periodic checking of the electronic circuitry and the connection between the electrode and the controller. This self-checking is generated by simulating a loss of water. In order to avoid disturbances to the safety system, caused by waves in the boiler water, the signal generated by the RS-1 minimum level safety controller has a built in 5 second delay. This prevents shutdowns caused by spurious failures.

Operation

The green operation lamp is on when the RS-1 minimum level safety controller is energized indicating that there is sufficient water in the boiler.

The RS-1 minimum level safety controller is equipped with buttons for manual checking:

1-Checking electrode (measuring probe): When this button is pressed for 5 seconds the electronic circuit and the connection between controller and electrode are checked. The simulation of water loss caused by cutting the voltage to the electrode causes a shutdown of the relay. The operation lamp goes off, the failure signal is activated and the burner is disconnected.

2-Isolation checking: When this button is pressed for 5 seconds the isolation is checked. The isolation of electronic circuitry and the steam-water compensation tube of the ES-1 minimum level safety electrode is checked, i.e. that there is no short-circuit or leakage to earth. The simulation of loss of isolation causes a shutdown of the relay. The operation lamp goes off, the failure signal is activated and the burner is disconnected.

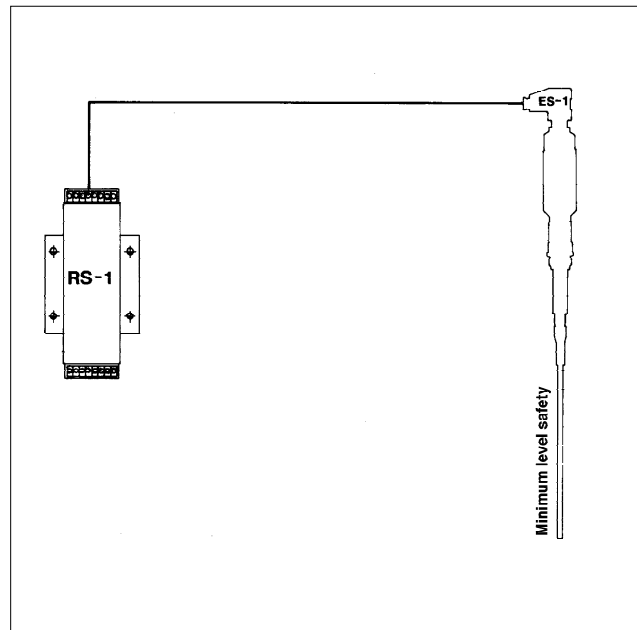

Maintenance

The RS-1 minimum level safety controller, as it is self-checking, only requires a 6 monthly inspection by a qualified technician. We recommend carrying out the above mentioned manual checks once or twice per week.

Check the electrode measuring probe every 6 months and clean thoroughly.

After every change of controller or electrode, the correct functioning of the controls should be checked before putting the boiler back in service.

Breakdown

The RS-1 minimum level safety controller is an electronic device which is not subject to any mechanical wear or breakage.

In the unlikely case of breakdown:

- Check the boiler water level.
- Check the RS-1 minimum level safety controller fuse (M.250/0,20A).
- Check the connection between controller and electrode (RS-1/ES-1).
- Change the RS-1 minimum level safety controller. If the failure continues the failure is caused by the ES-1 minimum level safety electrode.

VYC controllers and electrodes are officially approved by several international organisations and must be repaired only in our workshops.

Electrodes

Connection:

- Whitworth gas-tight cylindrical male thread ISO 228/1 1978 (DIN-259) 1".
- NPT thread ANSI-B2.1 via adapter. 1" F-GAS to 1" or 1 1/4" M-NPT. Mod.176 ES-1 only 1"x1 1/4".

Maximum operating temperature: 238°C.

Maximum operating pressure: 32 bar.

Protection: IP-65.

MODEL	EN-1	ES-1
R	1"	1"
H	952	952
H ¹	700	700
h ¹	252	252
h ²	153	153
h ³	547	547
L	53	53
WEIGHT IN Kgs.	1,09	1,12
CODE 2104 - 176.	71021	71022

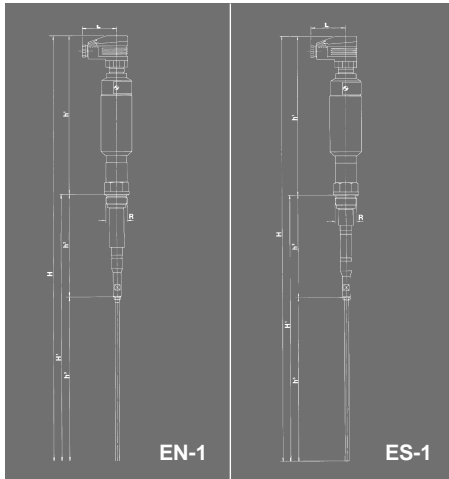

Electrode connection collector

As the body of the boiler cannot be perforated, the electrode connection collector allows the boiler to be equipped with an electrode based electronic level control device or the substitution of an old buoy type automatic level controller.

Nominal pressure: PN-40.

Allowable pressures and temperatures according to DIN-2401. Sheet 2.

Flange connection: DN-25 (EN-1092-1).

Electrode connection: Whitworth gas-tight cylindrical female thread ISO 228/1 1978 (DIN-259) 1".

We recommend adding a blowoff valve to the equipment, Mod. 999, 1/2" joined to the waste pipe for periodic release of sludge. As a minimum a 2 ÷ 3 second release must be performed every 8 hours.

If an electrode connection is to be taken out of service, the necessary plugs and seals can be supplied.

DN	25	25	25	25
R	1"	1"	1"	1"
h ¹ (1)	190	190	250	250
Nº. OF ELECTRODE CONNECTIONS	1	3	1	3
H	650	650	680	680
H ₁	529	529	559	559
h ²	205	205	175	175
L	159	159	159	159
R ₁	1/2"	1/2"	1/2"	1/2"
L ₁	100	100	100	100
L ₂	102	102	102	102
D	115	115	115	115
K	85	85	85	85
I	14	14	14	14
b	18	18	18	18
DRILLS N°.	4	4	4	4
WEIGHT IN Kgs.	10,90	10,70	11,50	11,30
CODE 2104 - 176.	83441	83442	83443	83444

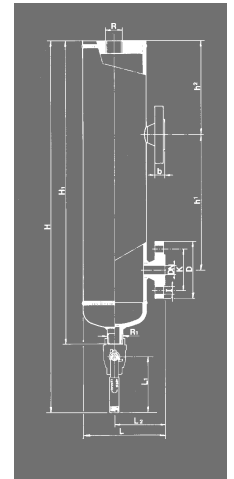

(1) Can be manufactured with other distances between centres of flanges.

Controllers

Voltage: 220 V.A.C. ± 10% 50/60 Hz.

Electrical consumption: Approximately 6 VA. (RN-1), 10 VA. (RS-1).

Relay contact: 250 V., 5 A.

Electrode circuit voltage: Galvanically isolated from mains. 7V. AC.

Output relays delay on deenergising: 10 seconds (RN-1), 5 seconds (RS-1).

Minimum operating conductivity: 3 µs/cm (RN-1), 0,05 ÷ 1 µs/cm (RS-1).

Ambient temperature: 0 to 55°C.

Controller protection: IP-10.

The controllers are supplied in an individual 19" sub-rack DIN-41494. If specified, we can supply from 2 to 5 controllers in the same sub-rack, and also include the desalting controller RD-1 in the assembly. (See brochure Model 560-A).

MODEL	RN-1	RS-1	19" sub-rack for controller mounting				
			1	2	3	4	5
H	157	157	157	157	157	157	157
F	210	210	210	210	210	210	210
F ¹	189	189	189	189	189	189	189
F ²	17	17	17	17	17	17	17
L	86	86	86	132	177	223	269
K	52	52	52	98	143	189	235
K ¹	72	72	72	118	163	209	255
K ²	57	57	57	57	57	57	57
I	6	6	6	6	6	6	6
WEIGHT IN Kgs.	0,90	0,90	0,32	0,37	0,43	0,48	0,53
CODE 2104 - 176.	0001	0002	00001	00002	00003	00004	00005

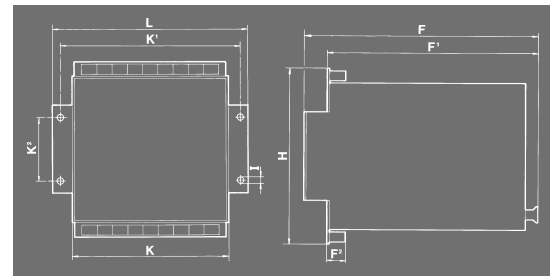

Installation examples

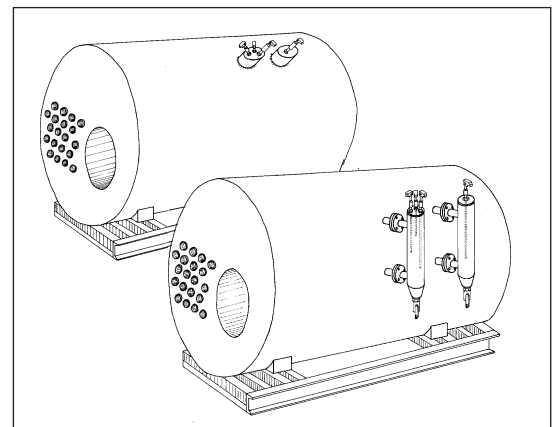

VYC industrial, sa
Founded in 1914

www.vycindustrial.com

Avenc del Daví, 22 Pol. Ind. Can Petit 08227 TERRASSA (Barcelona) SPAIN

+34 93 735 76 90

+34 93 735 81 35

✉ 119

@ info@vycindustrial.com

Informative brochure, without obligation and subject to our General Sales Conditions.